

**CS 2200**

**User Guide**

# Notice

Congratulations on your purchase of the CS 2200. Thank you for your confidence in our products and we will do all in our power to ensure your complete satisfaction.

The User Guide for the CS 2200 includes information on the usage of the equipment. We recommend that you thoroughly familiarize yourself with this Guide in order to make the most effective use of your system.



**WARNING: We recommend that you consult the “Safety, Regulatory and Technical Specification User Guide” before using the CS 2200.**

No part of this Guide may be reproduced without the express permission of Carestream Health, Inc.

U.S. Federal law restricts this equipment to sale by or on the order of a dentist or physician.

This document is originally written in English.

Manual Name: *CS 2200 User Guide*

Part Number: SM761

Revision Number: 02

Print Date: 2014-01

CS 2200 complies with Directive 93/42/EEC relating to medical equipment.



0086

## Contents

**1—About This Guide**

Conventions in this Guide . . . . .	1-1
-------------------------------------	-----

**2—CS 2200 SYSTEM OVERVIEW**

General Overview . . . . .	2-1
CS 2200 Unit Configurations . . . . .	2-4
Control Timer Unit . . . . .	2-10

**3—CS 2200 RADIOLOGY PROCESS**

Positioning . . . . .	3-1
Positioning the Patient . . . . .	3-1
Positioning the X-Ray Generator . . . . .	3-1
Paralleling technique . . . . .	3-1
Bisecting technique . . . . .	3-2
Positioning the Imaging Receptor . . . . .	3-2
Exposure . . . . .	3-2
Exposure Parameters . . . . .	3-2
Exposure Times . . . . .	3-3
Emitted Doses . . . . .	3-5
Film Processing . . . . .	3-7

**4—ACQUIRING AN IMAGE**

Preparing for Image Acquisition . . . . .	4-1
Launching the X-Ray . . . . .	4-2
Setting the Mode . . . . .	4-2

**5—USER MODE**

Parameters . . . . .	5-1
Entering the User Mode . . . . .	5-1
Modifying Parameters . . . . .	5-2
Exiting the User Mode . . . . .	5-2
Performing a Tube Seasoning . . . . .	5-2
Automatic Tube Seasoning . . . . .	5-2
Manual Tube Seasoning . . . . .	5-3

**6—TROUBLESHOOTING**

Quick Troubleshooting . . . . .	6-1
Information Messages . . . . .	6-3
Error Messages . . . . .	6-4

**7—MAINTENANCE**

Quarterly . . . . .	7-1
Generator . . . . .	7-1
Mechanical support . . . . .	7-1

Control timer unit and electrical installation. . . . . 7-1  
Operation. . . . . 7-1  
Control timer unit self-test . . . . . 7-1  
Annually . . . . . 7-2  
Cleaning and Disinfecting the CS 2200 . . . . . 7-2

**8—CONTACT INFORMATION**

Manufacturer’s Address. . . . . 8-1  
Authorized Representatives. . . . . 8-1

# Chapter 1

## About This Guide

### Conventions in this Guide

The following special messages emphasize information or indicate potential risk to personnel or equipment:

***WARNING***

Warns you to avoid injury to yourself or others by following the safety instructions precisely.

***CAUTION***

Alerts you to a condition that might cause serious damage.

***IMPORTANT***

Alerts you to a condition that might cause problems.

***NOTE***

Emphasizes important information.

***TIP***

Provides extra information and hints.

***WARNING***

Exposure to ionizing radiation



## Chapter 2

# CS 2200 SYSTEM OVERVIEW

The CS 2200 is compliant with the requirements of the EEC and international medical standards.

The CS 2200 unit has been designed to produce high-quality intraoral radiographies that:

- Reveal maximum details with the minimum dose to the patient.
- Show teeth and anatomic structures accurately with a minimum of distortion or magnification.
- Have optimal density and contrast to maximize their use for the detection of dental diseases.

The CS 2200 uses a high frequency technology that allows:

- Reduced X-ray doses for patients because the CS 2200 unit emits fewer soft rays absorbed by patients which are not used during image creation.
- Shorter exposure times which reduce the risk of motion blur during exposure

The CS 2200 is equipped with a thermal safety system that prevents the generator from overheating in case of intensive use. This prohibits any exposure as long as the generator has not cooled down. The I01 error message appears on the display, a red LED lights up on the control timer unit and an audible beep is heard during the unit cooling period. The beep stops when the cooling period is over.

To obtain high-quality intraoral radiography with maximum details, you must be very careful when performing the three steps of the radiography process:

- Positioning the patient, the x-ray generator, and the imaging system
- Setting the exposure parameters according to the imaging receptor used (film, phosphor plates or sensor)
- Processing the film (if a conventional film is used.)

## General Overview

The CS 2200 unit is composed of the following functional components

- A high-frequency X-ray generator which includes:
  - A transformer and associated electronics, and an oil-bathed x-ray tube
  - A beam limiting device with the following characteristics:
    - A radiation diameter of 6 cm (2.36 in.)
    - A distance from the X-ray tube focal spot to skin of 20 cm (8 in.).
- An angle scale and handle to facilitate positioning.

- A wall framework which contains the:
  - Main powerboard
  - ON/OFF switch which contains a built-in LED.
- A control timer unit which:
  - Performs anatomical selection and displays parameters (exposure time and emitted dose).
  - Performs a microprocessor self-test at every unit activation.
  - Displays alarms in case of incorrect operation.
  - Includes two preset modes and a manual setting mode.
- An extension arm and a scissor arm which is equipped with springs that ensure arm stability.

The following figure illustrates the extension arm and the scissor arm.

**Figure 2-1 CS 2200 - Side View**

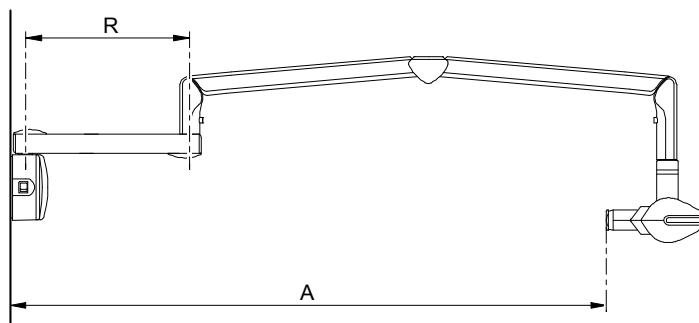

**Table 2-1 Extension arm types**

Extension	R	Span A
Short	47.0 cm (18.5 in.)	170.0 cm (67 in.)
Standard	64.8 cm (25.5 in.)	188.0 cm (74 in.)
Long	82.5 cm (32.5 in.)	205.0 cm (80.69 in.)

- A rectangular collimator. Its various sizes adapt to films, phosphor plates and RVG sensors. It is recommended to use such a collimator if possible, in order to limit the radiation absorbed by patients.



---

The CS 2200 unit is also composed of the following optional accessories:

- A separate timer box
- A remote exposure switch.

The following CS 2200 unit configurations are provided:

- Standard wall-mounted unit
- Wall-mounted unit for Irix replacement
- Ceiling-mounted unit.

The following mounting options are provided:

- Floor column base
- Mobile base



**NOTE**

These options must be used with a standard wall-mounted unit.

# CS 2200 Unit Configurations

Figure 2-2 Standard CS 2200 Unit.

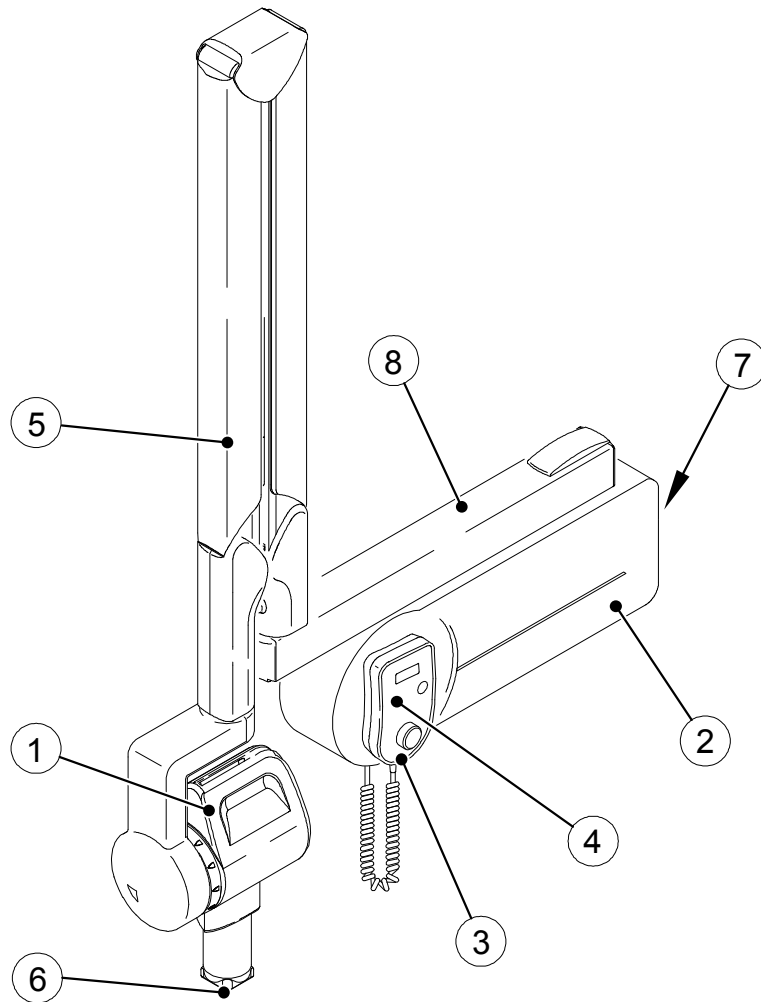

1	High frequency X-ray generator
2	Wall framework
3	Control timer unit
4	X-ray exposure button
5	Scissor arm
6	Rectangular collimator
7	ON/OFF switch with built-in LED
8	Extension arm

Figure 2-3 Standard CS 2200 Unit. with Separate Control Timer Unit

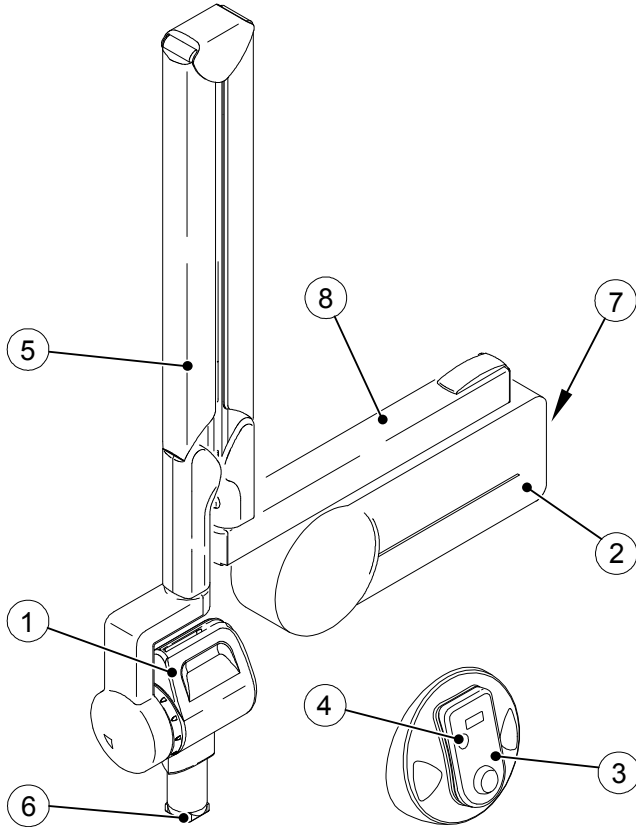

1	High frequency X-ray generator
2	Wall framework
3	Separate control timer unit
4	X-ray exposure button
5	Scissor arm
6	Rectangular collimator
7	ON/OFF switch with built-in LED
8	Extension arm

**Figure 2-4 Wall-Mounted Unit for Irix Replacement**

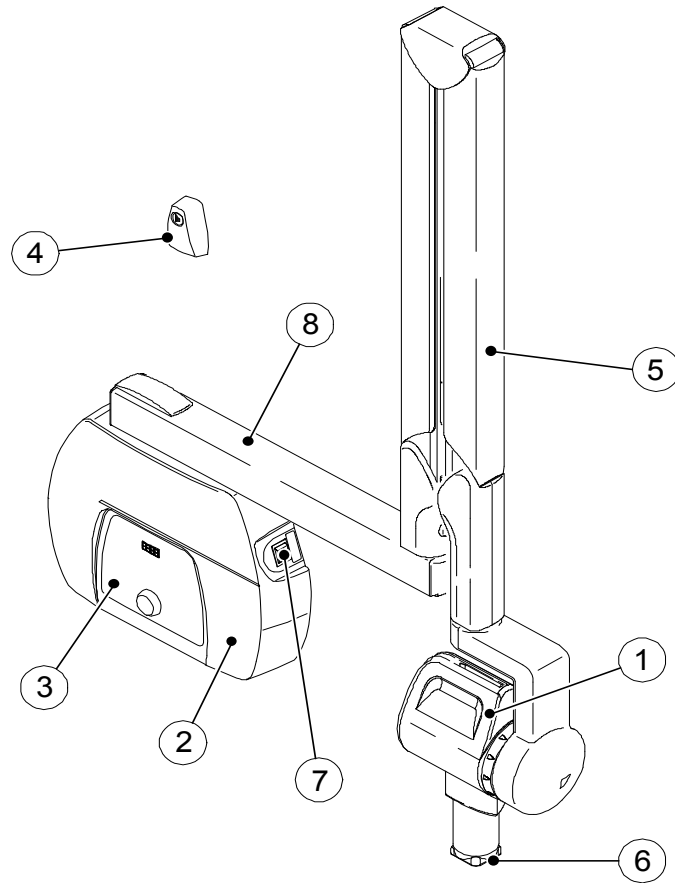

1	High frequency X-ray generator
2	Wall framework
3	Control timer unit
4	Separate exposure switch
5	Scissor arm
6	Rectangular collimator
7	ON/OFF switch with built-in LED
8	Extension arm

Figure 2-5 Ceiling-Mounted Unit

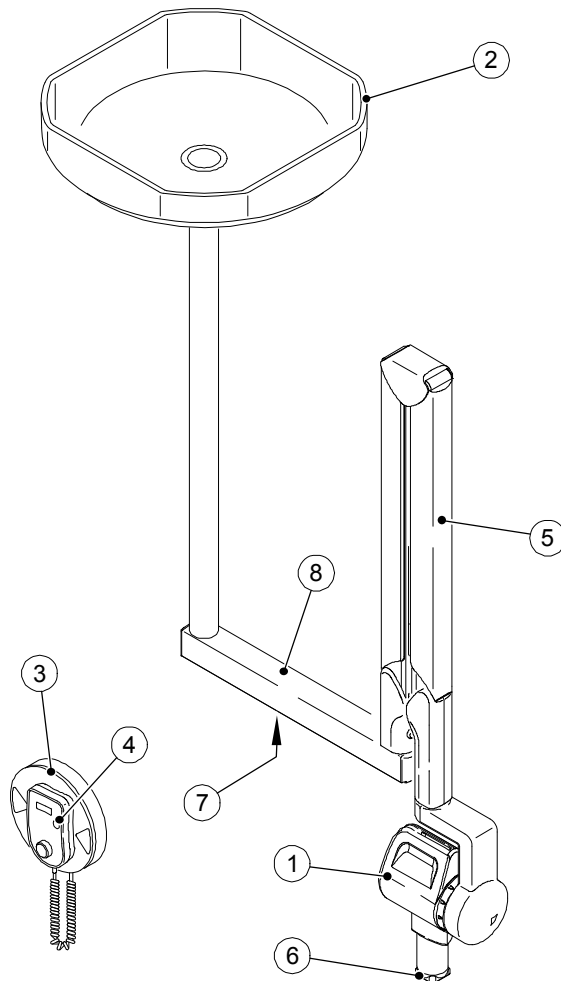

1	High frequency X-ray generator
2	Ceiling mounted unit containing the main powerboard
3	Control timer unit
4	X-ray exposure switch
5	Scissor arm
6	Rectangular collimator
7	ON/OFF switch with built-in LED
8	Extension arm

Figure 2-6 Unit Mounted on Floor Column

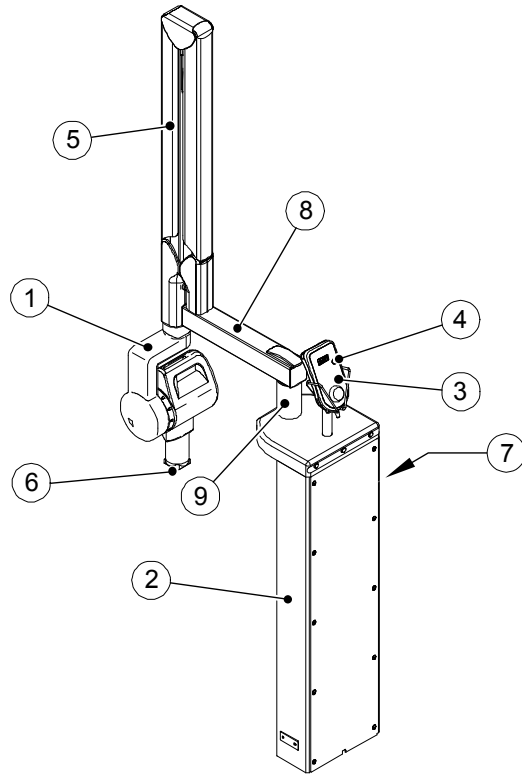

1	High frequency X-ray generator
2	Floor column containing the main powerboard
3	Control timer unit
4	X-ray exposure button
5	Scissor arm
6	Rectangular collimator
7	ON/OFF switch with built-in LED
8	Extension arm
9	Raiser

Figure 2-7 Unit Mounted on Mobile Base

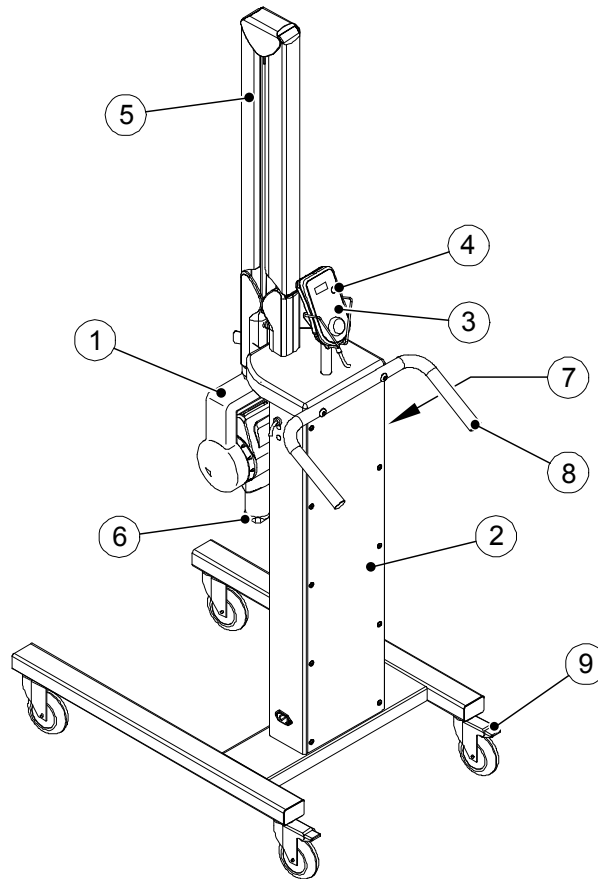

1	High frequency X-ray generator
2	Mobile stand containing the main powerboard
3	Control timer unit
4	X-ray exposure button
5	Scissor arm
6	Rectangular collimator
7	ON/OFF switch with LED
8	Handle
9	Foot brake

## Control Timer Unit

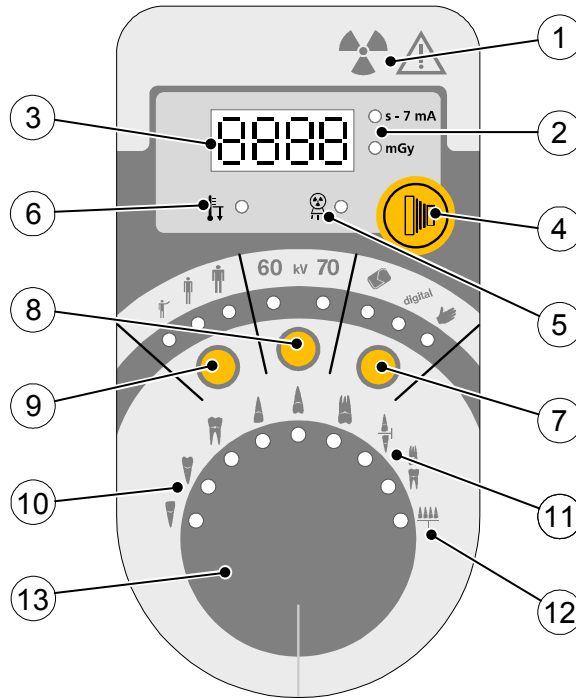

1	Warning: Ionizing radiation
2	Exposure time - emitted dose indicator
3	Display
4	X-ray exposure button  <b>NOTE</b>  For the Irix mount configuration, the X-ray exposure button is remote.
5	X-ray emission control light
6	Cooling indicator
7	Receptor selector (2 preset modes, 1 manual mode)
8	kV selector
9	Child / Adult (standard) / Adult (large) selector
10	Tooth selector
11	Bitewing selector
12	Occlusal selector
13	Selection knob: - Preset mode: Rotate the knob to select the tooth - Manual mode: Rotate the knob to select the exposure time.



## Chapter 3

# CS 2200 RADIOLOGY PROCESS

## Positioning

### Positioning the Patient

To position the patient, you must have:

- The patient sit with the vertical sagittal plane.
- The patient's head positioned as follows:
  - For upper maxillary radiography, the Frankfort plane (nose-ear plane) must be horizontal.
  - For lower maxillary radiography, the occlusal plane must be horizontal.

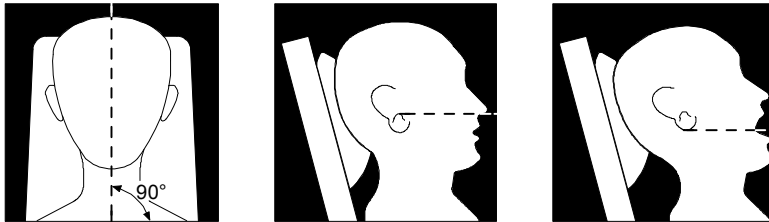

### Positioning the X-Ray Generator

The scissor arm allows you to accurately position the generator for any type of exposure. The beam-limiting device maintains a distance of at least 20 cm (8 in.) between the focal spot and the skin, which allows you to use either the paralleling or the bisecting technique.

#### Paralleling technique

The positioning tool used in the paralleling technique allows you to align the beam and the image receptor. An appropriate collimator reduces the dosage by limiting the surface exposure.

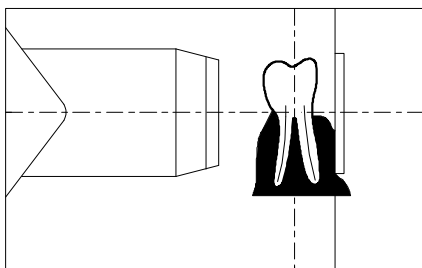

## Bisecting technique

When using the bisecting technique, do not use a rectangular collimator. This limits the risk of X-ray beam and image receptor misalignment.

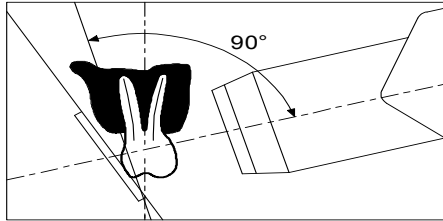

## Positioning the Imaging Receptor

Using the CS 2200, you may create an X-ray image on one of the following image receptors:

- Conventional silver halide films, such as KODAK dental films.
- Digital sensors such as RVG sensors.
- Phosphor plate such as CS Imaging plates.

Placing the receptor correctly is critical. Check your own dental radiography manual for information on how to place the imaging receptor correctly.

If you do not position the film or the sensor correctly, this results in errors on the radiography, such as distorted teeth and roots, elongation, magnification, and/or overlapping contacts. The paralleling technique generally reduces the risk of such errors. However, if you do not position the system correctly, angulation errors can occur (angulation of the receptor to the tooth itself).

If the beam exit pattern is not aligned with the imaging receptor, then part of the radiography will not be exposed to radiation and the final radiography will have some clear (unexposed) areas. This defect is called "cone cuts".

The imaging receptor is marked to indicate the tube side. If the orientation is not correct, the resulting radiography is lighter and may show artifacts, such as foil pattern or sensor cable.

## Exposure

### Exposure Parameters

Since each receptor (film, digital sensor, or phosphor plate) has its own sensitivity to X-ray radiation, the receptor choice impacts the exposure parameters. For instance, the sensitivity class for conventional dental films is characterized with the letter D, E, or F where F is more sensitive than E, and E more sensitive than D. Consequently, the required dose for the correct exposure goes down as sensitivity increases.

Due to the different sensitivity of the digital sensors, you also need to adjust the exposure parameters to the used sensor type.

The CS 2200 allows you to use two different modes with pre-set exposure times. These modes are programmed when installing the equipment based on your local imaging systems, as indicated in Tables 3-3 to 3-5. These tables meet the manufacturer's standard conditions and should only be used as guidelines.

You can modify these settings to:

- Adjust your exposure settings as needed, based on the results obtained from your system exposure and processing.
- Adjust your exposure settings after a change to your imaging system.

To modify the settings, start the "Setting the Mode" procedure.

The CS 2200 also allows you to use the manual mode where you select the exposure time directly.

## Exposure Times

Tables 3-1 and 3-2 indicate exposure times that were defined based on a unit equipped with a standard cone of 20 cm (8 in.) focus-to-skin distance.

**Table 3-1 Exposure Times in Seconds for class D-Speed Films**

Maxillary	70 kV - 7 mA)			60 kV - 7 mA		
	Child	Adult (Standard)	Adult (Large)	Child	Adult (Standard)	Adult (Large)
Incisor / Bicuspid	0.119	0.180	0.227	0.238	0.360	0.454
Premolar	0.152	0.230	0.290	0.304	0.460	0.580
Molar	0.178	0.270	0.340	0.356	0.540	0.680
<b>Mandibular</b>						
Incisor / Bicuspid	0.099	0.150	0.189	0.198	0.300	0.378
Premolar	0.106	0.160	0.202	0.211	0.320	0.403
Molar	0.119	0.180	0.227	0.238	0.360	0.454
<b>Bitewing</b>						
Anterior	0.099	0.150	0.189	0.198	0.300	0.378
Posterior	0.119	0.180	0.227	0.238	0.360	0.454
<b>Occlusal</b>						
	0.205	0.310	0.391	0.409	0.620	0.781

**Table 3-2 Exposure Time Corrections based on Selected Setting**

Setting	Correction	Coefficient
S01	-92%	0.08
S02	-90%	0.10
S03	-88%	0.125
S04	-84%	0.16
S05	-80%	0.20
S06	-75%	0.25
S07	-68%	0.31
S08	-60%	0.40
S09	-50%	0.50
S10	-37%	0.63
S11	-21%	0.79
S12	0%	1.00
S13	+26%	1.26
S14	+56%	1.56
S15	+100%	2.00
S16	+152%	2.52

**Table 3-3 Film Types**

Brand	Name	Setting
KODAK	Insight	S 08
KODAK	E-speed	S 09
KODAK	Ultra-speed	S 12
KODAK	D-speed	S 12
Other films	Speed class F	S 08 or S 09
Other films	Speed class E	S 09 or S 10
Other films	Speed class D	S 12 or S 13

**Table 3-4 Sensor Types**

Brand	Name	Setting
Trophy	RVG Reference High Sensitive mode	S 02
Trophy	RVGui High Sensitive mode	S 02
Trophy	RVG Ultimate size 0	S 05
Trophy	RVG THD	S 05
Trophy	RVG 6500 size 0	S 05
Trophy	RVG 6100 size 0	S 05
Trophy	RVG 6500 size 1 & 2	S 07
Carestream	RVG 6100 size 1 & 2	S 07
Carestream	RVG 6000	S 07
Trophy	RVG Ultimate	S 07
Trophy	RVG Reference High Resolution mode	S 07
Trophy	RVGui High Resolution mode	S 07
Trophy	RVG Exclusive	S 07
Carestream	RVG 5100	S 08
Carestream	RVG 5000	S 08
Trophy	RVG Access	S 08
Trophy	RVG Element	S 08
Other brands		Adjust setting accordingly

**Table 3-5 Storage Phosphor Plates**

Brand	Name	Setting
Carestream	CR 7400	S 12
Carestream	CS 7600	S10
Other brands		Adjust setting accordingly

## Emitted Doses

To obtain the dose in  $\text{mGy}\cdot\text{cm}^2$ , multiply the values listed in table 3-6 by the exposed surface. The exposed surface depends on the collimator type used as indicated in table 3-7.

**Table 3-6 Measured Dose at the End of the 20 cm (8 in.) Cone**

70 kV - 7 mA						60 kV - 7 mA							
t(s)	D mGy	t(s)	D mGy	t(s)	D mGy	t(s)	D mgY	t(s)	D mGy	t(s)	D mGy	t(s)	D mgY
0.010	0.09	0.260	2.22	0.510	4.36	0.760	6.49	0.010	0.06	0.260	1.58	0.520	3.17
0.020	0.17	0.270	2.31	0.520	4.44	0.770	6.58	0.020	0.12	0.270	1.64	0.540	3.29
0.030	0.26	0.280	2.39	0.530	4.53	0.780	6.66	0.030	0.18	0.280	1.71	0.560	3.41
0.040	0.34	0.290	2.48	0.540	4.61	0.790	6.75	0.040	0.24	0.290	1.77	0.580	3.53
0.050	0.43	0.300	2.56	0.550	4.70	0.800	6.83	0.050	0.30	0.300	1.83	0.600	3.65
0.060	0.51	0.310	2.65	0.560	4.78	0.810	6.92	0.060	0.37	0.310	1.89	0.620	3.78
0.070	0.60	0.320	2.73	0.570	4.87	0.820	7.00	0.070	0.43	0.320	1.95	0.640	3.90
0.080	0.68	0.330	2.82	0.580	4.95	0.830	7.09	0.080	0.49	0.330	2.01	0.660	4.02
0.090	0.77	0.340	2.90	0.590	5.04	0.840	7.17	0.090	0.55	0.340	2.07	0.680	4.14
0.100	0.85	0.350	2.99	0.600	5.12	0.850	7.26	0.100	0.61	0.350	2.13	0.700	4.26
0.110	0.94	0.360	3.07	0.610	5.21	0.860	7.34	0.110	0.67	0.360	2.19	0.720	4.38
0.120	1.02	0.370	3.16	0.620	5.29	0.870	7.43	0.120	0.73	0.370	2.25	0.740	4.51
0.130	1.11	0.380	3.25	0.630	5.38	0.880	7.52	0.130	0.79	0.380	2.31	0.760	4.63
0.140	1.20	0.390	3.33	0.640	5.47	0.890	7.60	0.140	0.85	0.390	2.38	0.780	4.75
0.150	1.28	0.400	3.42	0.650	5.55	0.900	7.69	0.150	0.91	0.400	2.44	0.800	4.87
0.160	1.37	0.410	3.50	0.660	5.64	0.910	7.77	0.160	0.97	0.410	2.50	0.820	4.99
0.170	1.45	0.420	3.59	0.670	5.72	0.920	7.86	0.170	1.04	0.420	2.56	0.840	5.12
0.180	1.54	0.430	3.67	0.680	5.81	0.930	7.94	0.180	1.10	0.430	2.62	0.860	5.24
0.190	1.62	0.440	3.76	0.690	5.89	0.940	8.03	0.190	1.16	0.440	2.68	0.880	5.36
0.200	1.71	0.450	3.84	0.700	5.98	0.950	8.11	0.200	1.22	0.450	2.74	0.900	5.48
0.210	1.79	0.460	3.93	0.710	6.06	0.960	8.20	0.210	1.28	0.460	2.80	0.920	5.60
0.220	1.88	0.470	4.01	0.720	6.15	0.970	8.28	0.220	1.34	0.470	2.86	0.940	5.72
0.230	1.96	0.480	4.10	0.730	6.23	0.980	8.37	0.230	1.40	0.480	2.92	0.960	5.85
0.240	2.05	0.490	4.18	0.740	6.32	0.990	8.45	0.240	1.46	0.490	2.98	0.980	5.97
0.250	2.14	0.500	4.27	0.750	6.41	1.000	8.54	0.250	1.52	0.500	3.05	1.000	6.09

**NOTE**

Dose accuracy: +/- 30% (mGy)

**Table 3-7 Exposure Surface versus Collimator Type**

Collimator type	Format (cm)	Used with digital sensor	Used with film or phosphor plate (cm)	Exposure surface (cm <sup>2</sup> )
A	1.9 x 2.4	Size 0	-	4.6
B	2.3 x 3.5	Size 1	Size 0: 2.2 x 3.5	8.3
C	3.1 x 3.9	Size 2	Size 1: 2.4 x 4.0 Size 2: 3.1 x 4.1	12.1
Standard cone	6.0 cm diameter	-	Size 3: 2.7 x 5.4 Size 4: 5.7 x 7.6	28.3

## Film Processing

When using conventional films, you must process the film according to the manufacturer's instructions. Process the film under safelight conditions manually or using an automatic processor.

If you use an automatic processor, see the processor's manual. Check that the processor maintenance is performed regularly.

If you process the film manually, follow precisely the manufacturer's recommendations for solution preparation, processing time, and solution temperature for both developer and fixer baths. Any deviation from the manufacturer's recommendations (such as a solution that would be too concentrated or diluted, too hot or cold, or if the film processing duration is incorrect) will impact the final radiography quality.

Before archiving, do not forget to wash the film correctly and to dry it in a clean place.





## Chapter 4

# ACQUIRING AN IMAGE

This chapter describes the various tasks that you must perform for image acquisition. To acquire an image, you can use conventional films or digital receptors.

If necessary, for example after a long inactivity period of the CS 2200 system, we recommend to start with the tube seasoning procedure. For more information, see the “Tube Seasoning Procedure”.

## Preparing for Image Acquisition

To prepare for image acquisition, follow these steps:

1. Switch ON the unit.

The green indicator of the ON/OFF button lights up

When you switch ON the unit, a self-test starts automatically. It checks the display. When the test is completed, a short beep sounds. If an error occurs, an error code appears. For error messages, see the “Troubleshooting” section.

2. From the control timer unit, select the exposure mode using 

When the correct mode is displayed, the corresponding indicator lights up.

3. From the control timer unit, press on  to select the kV value:

- 60 kV for high-contrast radiographies, which gives a clear image of the endodontal instruments or clearly displays a tooth decay.
- 70 kV for low-contrast radiographies which provide wider latitude and more grey levels. This is useful for periodontal work.

The corresponding LED indicates the current selection

4. From the control timer unit, press on  to select the patient type: Child, Adult (standard), or Adult (large),

5. Turn  to select the:

- Tooth when using the automatic mode or the bitewing or occlusal program.
- Exposure time when using the manual mode.

The unit is now ready for acquisition.



### **IMPORTANT**

**The operator must instruct the patient to refrain from moving during the entire exposure.**

## Launching the X-Ray

To launch the X-ray, follow these steps:



### WARNING

Be careful not to be exposed to ionizing radiation

1. Press  from the control timer unit or from the X-ray exposure switch.

The X-ray emission indicator lights up and a beep is heard.

2. Keep pressing  until the X-ray emission indicator is OFF and the beep stops.

During the exposure, the exposure time counts off on the display.



### CAUTION

If you release the button before the end of the X-ray, a manipulator alarm (E01) is enabled.

This indicates that the X-ray emission was aborted prematurely. There is an underexposure risk. Depending on the remaining time, you can decide to process the image or start a new acquisition.

To stop the alarm, press on  from the control timer unit.

When the acquisition is completed, the emitted dose is displayed in mGy. The “mGy” indicator lights up. For information on the emitted doses based on the exposure times, see Table 3-6. The latest parameter settings are kept until a new image acquisition is performed.



3. Press on  shortly to change from mGy to exposure time display.

## Setting the Mode

Setting the mode allows you to modify the exposure times according to the sensitivity of the used imaging system.

To set the mode, follow these steps:

1. Press  to select the preset mode to be modified.

2. Press and hold   simultaneously for at least three seconds until the display blinks.

3. If necessary, modify the setting by rotating  until the desired setting is displayed.

4. To validate, press and hold  until "COPY" is displayed.
5. To abort, press on the selection knob shortly.



## Chapter 5

# USER MODE

This chapter describes the various settings that you can select for the different pre-set modes. The user mode also allows you to validate specific local requirements for some countries.

## Parameters

**Table 5–1 Parameters Available through the User Mode**

Number	Parameters	Choice
P 03	Installation country	<p>0 for all countries except those having specific local requirements such as:</p> <ul style="list-style-type: none"> <li>• Australia: 61</li> <li>• Korea: 82</li> <li>• Kuwait: 965</li> </ul> <p> <b>NOTE</b> The specific country value is equal to the international telephone country code.</p>
P 4.1	Film mode setting	S 01 to S 16
P 4.2	Digital mode setting	S01 to S 16
P 05	Tube seasoning procedure	Switches from OFF to ON
P 06	Show mode	<p>ON: Disables the X-ray emission</p> <p>OFF (default value): Enables the X-ray emission</p>

## Entering the User Mode

To enter the user mode, follow these steps:

1. Switch ON the unit.

The self-test is enabled. While the self-test is in progress, the software information (for example, F718 x.x) is displayed.





2. Once F718 x.x is displayed, press shortly on  from the control timer unit.

You access the menu, when "USER" is displayed. The display intermittently shows the first parameter (P 03) and its setting (for example, "0").

3. To switch from one parameter to the other, turn  in any direction.

## Modifying Parameters

To modify parameters, follow these steps:

1. Turn  to select the parameter to modify.
2. Press  until "EDIT" is displayed and a beep is heard.  
The parameter value starts blinking.
3. Turn  to change the parameter value.
4. To validate, press and hold  for at least 3 seconds until "COPY" is displayed and a beep is heard.
5. To keep the initial value, press on  shortly. "ABOR" is displayed. The system returns to the parameter/program mode.

## Exiting the User Mode

To exit the user mode, press on  shortly. "QUIT" is displayed until the system returns to the operational mode. The self-test continues until it is completed.

## Performing a Tube Seasoning

### Automatic Tube Seasoning

This procedure allows for a progressive warm-up of the X-ray tube. It must be performed at unit installation and when replacing the tube head. It must also be done, for instance, after 3 weeks of equipment inactivity. It lasts for around three minutes.

To perform a tube seasoning, follow these steps:

1. Go to the User Mode menu and change parameter P 05 from OFF to ON.  
The self-test continues. After the self-test is completed, I 02 is displayed. This message means that the seasoning process must be started.
2. Press .  
The display blinks. The sequence step number and the required exposure settings (kV, time) are displayed alternatively.
3. Stand behind the generator.

4. Launch an X-ray.

**WARNING**

**Be careful not to be exposed to ionizing radiation**

When the exposure is completed, the display blinks. The cooling error code (I 01) and the remaining time required before the next step are displayed alternatively. The red light of the cooling cycle is lit.

When the cooling cycle is completed, the display blinks. The next step number and its exposure settings are displayed alternatively.

- 5 Repeat steps 3 and 4 until the end of the sequence.

Your system is ready.

## Manual Tube Seasoning

To perform a manual tube seasoning, follow these steps:

- 1 Select the following series of parameter settings: 60 kV - 7 mA - 0.5 s. Launch an X-ray.
2. Select the following series of parameter settings: 60 kV - 7 mA - 1 s. Launch an X-ray.
3. Select the following series of parameter settings: 60 kV - 7 mA - 1 s. Launch an X-ray.
4. Select the following series of parameter settings: 70 kV - 7 mA - 0.1 s. Launch an X-ray.
5. Select the following series of parameter settings: 70 kV - 7 mA - 0.5 s. Launch an X-ray.
6. Select the following series of parameter settings: 70 kV - 7 mA - 1 s. Launch an X-ray.

**IMPORTANT**

**If you receive error messages while you carry out the procedures, switch OFF and ON the unit and do all the procedures again.**

**If the error messages persists, contact your representative.**





## Chapter 6

# TROUBLESHOOTING

Occasionally, malfunctions can occur during use in the event of an incorrect action or failure. The quick troubleshooting, the Information “Ixx” and Error message “Exx” guide you through the actions you need to take to correct the malfunction.



### **IMPORTANT**

**If the malfunction persists or more serious conditions occur, switch OFF the unit power supply and contact your representative.**

When you call your representative, you must have the following information ready:

- Model Number: CS 2200
- Serial Number (on the labels)
- Error Code Number: E xx.

## Quick Troubleshooting

Quick troubleshooting guides you through the actions you need to take to correct the malfunctions.

The following table lists the malfunctions and the actions to take.

Malfunction	Possible Cause	Action
Nothing lights up	The unit power switch is OFF.	Switch ON the unit.
	The unit is electrically disconnected.	Connect the unit power supply cable.
	The circuit breaker is OFF.	Turn ON the circuit breaker
Control unit doesn't light up.	The control unit is defective or disconnected.	Call your representative.
No X-ray emission	The generator is cooling	Wait until message I01 and the red LED on the control key disappear.
	The X-ray exposure button is defective.	Call your representative.

Malfunction	Possible Cause	Action
The X-ray emission works, but the exposure is too light or completely white.	The wrong exposure preset program is being used.	Change the preset program (See the "Setting the Mode" procedure).
	The generator is not positioned correctly.	Adjust the generator position
	The exposure time is too short.	Increase the exposure time.
	The development time is too short.	Increase the development time (See the manufacturer's instructions).
	The developer is too cold.	Heat the developer
	The developer is too old or diluted.	Replace with a new developer
	The preset mode is not selected properly	Verify your exposure settings (See the exposure procedure).
	The receptor is not correctly positioned.	Reposition the receptor.
	The unit is not correctly installed.	Call your representative.
The X-ray emission works but exposure is too dark.	The wrong preset exposure program is being used	Change the preset program (See the "Setting the Mode" procedure).
	The exposure time is too long.	Reduce the exposure time.
	The development time is too long.	Reduce the development time (See the manufacturer's instructions).
	The developer is too hot.	Cool the developer
	The developer is too concentrated.	Adjust the concentration or change developer.
	The preset mode is not correctly selected.	Check your exposure settings (See the exposure procedure).

## Information Messages

An information “I” error code with a message appears on the display.

The following table lists the information messages and the actions to take.

**Table 1 Information Messages**

Information Code	Possible Cause	Action
I 01 and red LED lights up on the control timer unit.	Cooling cycle: this message can appear during intensive use period.	<p><b>Do not switch OFF the equipment.</b></p> <p>The information message disappears as soon as the system reaches a satisfactory temperature.</p>
I 02	Request for X-ray tube seasoning.	See the “User Mode” section.



### **IMPORTANT**

If you switch OFF the system, the microprocessor does not calculate the cooling time.

For safety reasons, it considers that the system has not gone through the cooling cycle.

## Error Messages

The following table lists the error messages and the actions to take.

**Table 2 Error Messages**

Error Message	Possible Cause	Action
E01 + audible alarm	The radiography control button was released before the exposure end. The display indicates the remaining exposure time. Based on this time, you must decide whether to develop the film or make another exposure.	Quickly press on the selection knob to stop the alarm.
E02 to E54	A component of your device may be faulty	Switch OFF, then restart the system. If the problem persists, contact your representative.

# Chapter 7

## MAINTENANCE

This chapter describes the maintenance tasks you must perform for your CS 2200.

### Quarterly

#### Generator

Check that:

- The certification label is legible.
- No oil leaks.

#### Mechanical support

Check that:

- The wall framework is securely attached to the wall.
- All labels are legible.
- The scissor arm is not worn out or damaged and is stable in all positions.
- The scissor arm plastic covers are firmly in place.

#### Control timer unit and electrical installation

Check that:

- The symbols are legible.
- The control timer unit and the power supply cables are in good condition.
- The X-ray exposure button returns to its initial position after use.

### Operation



#### WARNING

**Be careful not to be exposed to ionizing radiation**

Check that:

- The audible signal is heard and the X-ray emission indicator is visible when you make an exposure (manual mode, 60 kV, 0.1 sec).
- The "E01" message is displayed when you launch an X-ray (manual mode, 60 kV, 1.0 sec) and you release the control button before the exposure end.

#### Control timer unit self-test

To enable the self-test, you must switch ON the CS 2200 system.

- The self-test starts with a simultaneous display and alarm light test.

- Then, the system test starts. After the test is completed (indicated by a short beep), the firmware version and the total number of exposures (divided by 10) performed by the unit since first installation are displayed.
- If the test fails, an error message is displayed.



***IMPORTANT***

**If a check result is not satisfactory, stop using the equipment and contact your representative.**

## Annually

We recommend that an electrical, mechanical and dosimetric inspection of the unit be carried out by an authorized service technician provided by your representative.

## Cleaning and Disinfecting the CS 2200



***IMPORTANT***

**You must first clean the system before disinfection.**

To clean the system, follow these steps:

- 1 Clean the outside of the equipment with a damp paper towel or a soft cloth using an alcohol-based, non-corrosive cleaner.
- 2 Wipe off surfaces with either an intermediate disinfectant or a low-level disinfectant.



***CAUTION***

- Liquids must not drip into the equipment.
- Do not spray cleaner or disinfectant directly on the equipment.
- Follow the manufacturer's safety recommendations when using a cleaner or a disinfectant.

## Chapter 8

# CONTACT INFORMATION

## Manufacturer's Address

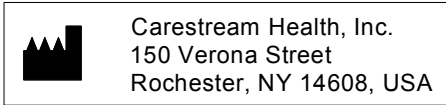

## Authorized Representatives

### Authorized Representative in the European Community

**EC REP**

TROPHY

4, Rue F. Pelloutier, Croissy-Beaubourg  
77435 Marne la Vallée Cedex 2, France

### Representante no Brasil Carestream do Brasil Comércio e Serviços de Produtos MédicosLtda.

Rua Pequetita, 215 cjs.  
31 E 32 Edifício Atrium VII - Vila Olímpia  
São Paulo - Brazil  
CEP (Zip code): 04552-060

