

PRODUCT CATALOG

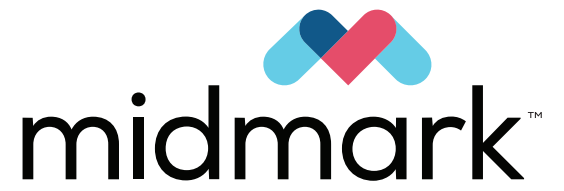

Designing better care™
for infection control



MIDMARK TABLETOP STERILIZERS

- **SHORTER CYCLES, LONGER LIFE:**
our validated and quicker programs ensure long life to your sterilizer.
- **PERFECT FOR YOUR NEEDS:**
chambers contain 6, 18, 23 or 60 litres and are made of thick one-piece moulded AISI 304 steel and AISI 316 for 60 L.
- **TROUBLE FREE:**
intelligent self-checking system alerts about maintenance needs.
- **EFFICIENT:**
more than 10 pre-set validated sterilizations programs.
- **SAFE:**
multiple sensors check working parameters adapting cycle times to internal and external conditions.
- **ACCURATE:**
the integrated water quality sensor constantly monitors the water quality. Only good quality water ensures a perfect sterilization and long life for your instruments and autoclave.
- **SIMPLE:**
easy to use by everyone, easy to service



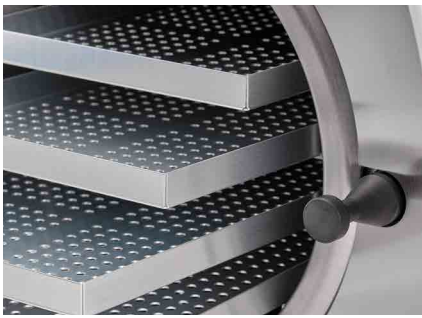

VSL - VACUUM SAFETY LOCKING:

door locking is motor operated and the chamber is vacuum-sealed right after. VLS technology guarantees total safety, greater ease of handling and reliable self regulation of the hatch.



BUILT-IN THERMAL PRINTER:

an automatic print-out records the entire procedure, thereby providing a permanent record of every sterilization cycle. The paper printout can then be kept and attached to your files for a complete and accurate record.



WATER QUALITY SENSOR:

our sterilizers are additionally protected by the inclusion of a water quality sensor, as standard. The quality of the water is therefore constantly monitored. The display informs the user whether water used for sterilization is good.



USB PORT:

automatic digital cycle recording on USB stick can be downloaded on your PC using our proprietary software (optional).



MULTILINGUAL & USER-FRIENDLY INTERFACE:

just four buttons for simpler navigation to all sterilization options. The LCD display shows current information about your sterilization cycles and alerts on errors or service needs.



WATER PURIFICATION SYSTEM:

with built-in **RO/OSI** (ROSI), tri-cartridge water purification system, your autoclave can be connected directly to your practice water supply, always ensuring good water to your sterilization process (optional).



MIDMARK 6 L

Sterilisation Table

	B6		S6				
DISPLAYED #, TEMPERATURE AND NAME	TYPE	TOTAL TIME	TYPE	TOTAL TIME	STERIZABLE LOAD <i>Load in (..) is sterilizable only in B-Class</i>	WRAPPED/ OPEN	
HELIX - B&D TEST	TEST	19'	TEST	35' B&D only	N/A	✗	
VACUUM TEST		15'		15'		✗	
121 °C HOLLOW WRAPPED	B	31'	S	45'	Solid Small porous Simple hollow Narrow lumen Multiple casing	✓	
134 °C HOLLOW WRAPPED		22'		35'		✓	
121 °C HOLLOW OPEN		27'	NOT PRESENT		Solid Small porous Simple hollow	✗	
134 °C HOLLOW OPEN		14'				✗	
134 °C PRION		34'			Load related to Creutzfeldt-Jakob disease	✓	
121 °C POROUS		38'	S	50'	Small sized porous + (Full porous)	✗	
134 °C POROUS		30'		40'		✓	
121 °C SOLIDS OPEN		S	21'	NOT PRESENT		Solid Simple hollow	✗
134 °C SOLIDS OPEN			12'				✗
134 °C SOLIDS WRAPPED			12'			Solid Simple hollow	✓
134 °C RAPID	NOT PRESENT		S	32'	Solid	✗	

WEIGHT	Solids wrapped: 1 kg unwrapped: 1.8 kg Porous: 0.5 kg	Solids wrapped: 1 kg unwrapped: 1.8 kg Porous: 0.5 kg
--------	--	--

NOTE: Narrow lumen is an item open on one side with length equal to 5 times (or more) the diameter.
Times are calculated in conditions of pre-warmed chamber.



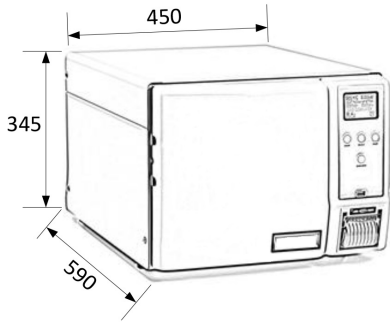

6 L

TECHNICAL DATA



B 6

B6

B6	S6 <small>REFERRING TO KRONOS S6</small>	
fractionated	pre and post vacuum	TYPE OF VACUUM
✓	-	INTEGRATED STEAM GENERATOR
Bowie&Dick Helix Vacuum	Bowie&Dick Vacuum	TEST PROGRAMS
✓		BUILT-IN PRINTER
		M.T.S MEMORY TEST SYSTEM
		WATER QUALITY SENSOR
		CONNECTION TO DATA LOGGER
optional		INTERNAL USB DATA LOGGER
450Wx590Dx345H mm		OVERALL MEASURES
ø170 x 265 mm		CHAMBER SIZE
nr. 3 aluminium trays: 1 tray 150Wx240Dx19H mm 2 trays 115Wx240Dx19H mm		TRAY SIZES
230V ± 10%		SUPPLY VOLTAGE
50-60 Hz		MAINS FREQUENCY
2500 W	1500 W	RATED POWER

MIDMARK 18 L

Sterilisation Table

	B18		S18		N18					
DISPLAYED #, TEMPERATURE AND NAME	TYPE	TOTAL TIME	TYPE	TOTAL TIME	TYPE	TOTAL TIME	STERIZABLE LOAD <i>Load in (..) is sterizable only in B-Class</i>	WRAPPED/ OPEN		
HELIX - B&D TEST	TEST	25'	TEST	28' B&D only	NOT PRESENT		N/A	✗		
VACUUM TEST		15'		15'				✗		
121 °C HOLLOW WRAPPED	B	40'	S	48'			NOT PRESENT	Solid Small porous Simple hollow + (Narrow lumen) (Multiple casing)	✓	
134 °C HOLLOW WRAPPED		29'		37'					✓	
121 °C SOLIDS WRAPPED	S	37'	S	45'			NOT PRESENT	Solid + (Small porous) (Simple hollow)	✓	
134 °C SOLIDS WRAPPED		25'		34'					✓	
134 °C PRION	B	44'	S	52'			N	45'	Load related to Creutzfeldt-Jakob disease	✓ / ✗ (B-S18/N18)
121 °C POROUS		50'		58'			NOT PRESENT		Small sized porous + (Full porous)	✓
134 °C POROUS		40'		48'						✓
121 °C RAPID	S	31'	S	39'			N	33'	Solid + (Small porous) (Simple hollow)	✗
134 °C RAPID		20'		28'	23'	✗				
134 °C HOLLOW OPEN	B	26'		34'	NOT PRESENT		Solid Simple hollow + (Narrow lumen)	✗		
121 °C SOLIDS OPEN	NOT PRESENT		NOT PRESENT		N	43'	Solid	✗		
134 °C SOLIDS OPEN						31'		✗		

WEIGHT	B18	S18	N18
	Solids wrapped: 2.5 kg unwrapped: 4 kg	Solids wrapped: 1 kg unwrapped: 2.5 kg	Solids using RAPID: 1.5 kg others: 3 kg
	Porous: 1 kg	Porous: 0.5 kg	

NOTE: Narrow lumen is an item open on one side with length equal to 5 times (or more) the diameter. Times are calculated in conditions of pre-warmed chamber.

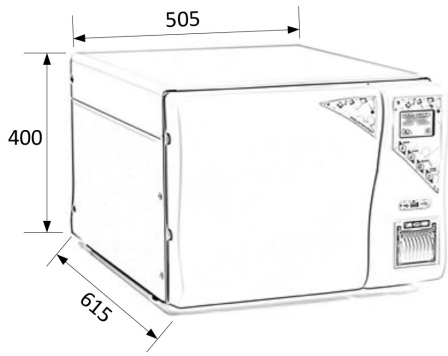

18 L

TECHNICAL DATA



B18

B18

B18	S18	N18	
fractionated	pre and post vacuum	Thermo-dynamic vacuum	TYPE OF VACUUM
<div style="text-align: center; font-size: 2em; color: #0070C0;">✓</div>			INTEGRATED STEAM GENERATOR
			BUILT-IN PRINTER
			M.T.S MEMORY TEST SYSTEM
			WATER QUALITY SENSOR
			CONNECTION TO EXTERNAL DATA LOGGER
optional			INTERNAL USB DATA LOGGER
			INTEGRATED WATER PURIFICATION SYSTEM "ROSI"
505Wx615Dx400H mm			OVERALL MEASURES
ø236x381,5 mm			CHAMBER SIZE
nr. 4 aluminium trays: 185Wx285Dx18H mm			TRAY SIZES
230 V ± 10%			SUPPLY VOLTAGE
50-60 Hz			MAINS FREQUENCY
2400 W			RATED POWER

MIDMARK 23 L

Sterilisation Table

	B23		S23		N23					
DISPLAYED #, TEMPERATURE AND NAME	TYPE	TOTAL TIME	TYPE	TOTAL TIME	TYPE	TOTAL TIME	STERIZABLE LOAD <i>Load in (..) is sterilizable only in B-Class</i>	WRAPPED/ OPEN		
HELIX - B&D TEST	TEST	35'	TEST	38' B&D only	NOT PRESENT	NOT PRESENT	N/A	✗		
VACUUM TEST		15'		15'				✗		
121 °C HOLLOW WRAPPED	B	50'	S	58'			NOT PRESENT	Solid Small porous Simple hollow + (Narrow lumen) (Multiple casing)	✓	
134 °C HOLLOW WRAPPED		39'		47'					✓	
121 °C SOLIDS WRAPPED	S	47'	S	55'			NOT PRESENT	Solid + (Small porous) (Simple hollow)	✓	
134 °C SOLIDS WRAPPED		35'		44'					✓	
134 °C PRION	B	54'	S	52'			N	55'	Load related to Creutzfeldt-Jakob disease	✓ / ✗ (B-S23/N23)
121 °C POROUS		60'		68'			NOT PRESENT	NOT PRESENT	Small sized porous + (Full porous)	✓
134 °C POROUS		50'		58'						✓
121 °C RAPID	S	41'	S	49'			N	43'	Solid + (Small porous) (Simple hollow)	✗
134 °C RAPID		30'		38'	33'	✗				
134 °C HOLLOW OPEN	B	36'		44'	NOT PRESENT	NOT PRESENT	Solid Simple hollow + (Narrow lumen)	✗		
121 °C SOLIDS OPEN	NOT PRESENT	NOT PRESENT	NOT PRESENT	NOT PRESENT	N	53'	Solid	✗		
134 °C SOLIDS OPEN						41'		✗		

WEIGHT	B23	S23	N23
	Solids wrapped: 3.5 kg unwrapped: 4.5 kg	Solids wrapped: 2 kg unwrapped: 3.5 kg	Solids using RAPID: 2.5 kg others: 4.5 kg
	Porous: 1.5 kg	Porous: 0.5 kg	

NOTE: Narrow lumen is an item open on one side with length equal to 5 times (or more) the diameter. Times are calculated in conditions of pre-warmed chamber.

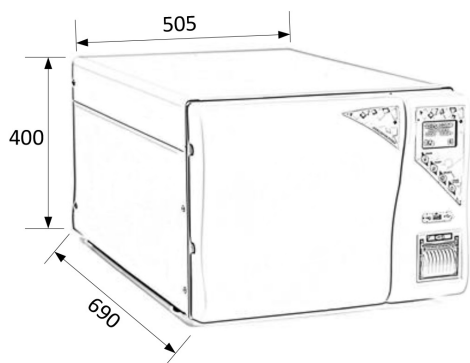

23 L



B23

TECHNICAL DATA

B23	S23	N23	
fractionated	pre and post vacuum	no vacuum	TYPE OF VACUUM
✓			INTEGRATED STEAM GENERATOR
			BUILT-IN PRINTER
			M.T.S MEMORY TEST SYSTEM
			WATER QUALITY SENSOR
			CONNECTION TO EXTERNAL DATA LOGGER
optional			INTERNAL USB DATA LOGGER
			INTEGRATED WATER PURIFICATION SYSTEM "ROSI"
505Wx690Dx400H mm			OVERALL MEASURES
ø236x530 mm			CHAMBER SIZE
nr. 4 INOX trays: 185Wx440Dx19H mm			TRAY SIZES
230 V ± 10%			SUPPLY VOLTAGE
50-60 Hz			MAINS FREQUENCY
2400 W			RATED POWER

MIDMARK 60 L



SMALL FOOTPRINT HUGE CAPACITY

- CAPACITY 60 LITERS
- BUILT-IN OSMOTIC SYSTEM
- DOUBLE VACUUM PUMP
- DOUBLE MOTOR-OPERATED LOCKING SYSTEM
- INTEGRATED USB STORAGE DEVICE
- ON BOARD PRINTER
- QUIKSTEAM PATENTED TECHNOLOGY
- ADDITIONAL DRYING OPTION
- « START DELAY » OPTION
- B/S/N-CLASS CYCLES INCLUDED



MIDMARK 60 L STERILIZERS ARE SUPPLIED WITH:

TRAYS HOLDER | ALUMINIUM TRAYS | CLEANING SPONGE | 1 SILICONE - INSULATED GLOVES | TUBES AND FITTING
CD SOFTWARE | OSMO3 PROTECTION FILTER

Sterilisation Table

DISPLAYED #, TEMPERATURE AND NAME		B60		B60 SI		STERIZABLE LOAD	WRAPPED/ OPEN
		TYPE	TOTAL TIME	TYPE	TOTAL TIME		
1	HELIX - B&D TEST	TEST	75'	TEST	45'	N/A	✗
2	VACUUM TEST		15'		15'		✗
3	121 °C HOLLOW WRAPPED	B	115'	B	73'	Solid Small porous Simple hollow Narrow lumen Multiple casing	✓
4	134 °C HOLLOW WRAPPED		110'		69'		✓
5	121 °C SOLIDS WRAPPED	S	100'	S	60'	Solid Small porous Simple hollow	✓
6	134 °C SOLIDS WRAPPED		95'		59'		✓
7	134 °C PRION	B	135'	B	72'	Load related to Creutzfeldt-Jakob disease	✓
8	134 °C POROUS		130'		89'		✓
12	134 °C SOLIDS OPEN	N	105'	N	68'	Solid	✓

WEIGHT	Solids wrapped: 12 kg Porous: 6 kg
---------------	---------------------------------------

NOTE: Narrow lumen is an item open on one side with length equal to 5 times (or more) the diameter. Times are calculated in conditions of pre-warmed chamber.

TECHNICAL DATA

B60	B60 SI	
fractionated		TYPE OF VACUUM
-	✓	INTEGRATED STEAM GENERATOR
Bowie&Dick/Helix/Vacuum		TEST PROGRAMS
✓		BUILT-IN PRINTER
		M.T.S MEMORY TEST SYSTEM
		INTERNAL USB DATA LOGGER
		CONNECTION TO DATA LOGGER
		WATER QUALITY SENSOR
		INTEGRATED WATER PURIFICATION SYSTEM
135 kg	138 kg	WEIGHT
655Wx850Dx755H mm		OVERALL MEASURES (WITHOUT CABINET)
ø350x622 mm		CHAMBER SIZE
nr. 4 aluminium trays: 2 trays 310Wx550Dx25H mm 2 trays 220Wx550Dx25H mm		TRAY SIZES
230 V ± 10% (1 phase)	400 V ± 10% (3 phases)	SUPPLY VOLTAGE
50-60 Hz		MAINS FREQUENCY
11 Amp	13 Amp per phase	RATED POWER

NOTE: The autoclave is a device designed for water steam sterilization of small professional tools and equipment and widely used for medical purposes, in general practitioners' and dentists' surgeries, in facilities dedicated to personal hygiene and care and in veterinary surgeries. It is also used to sterilize materials and equipment intended to come into contact with blood or bodily fluids, such as instruments used by beauticians, tattooists, body piercers and hairdressers. The very specific sterilization loads used in these sectors of application require a diversification of the requirements concerning performance characteristics for sterilization cycles. It is therefore recommended that the device be used by suitably trained professionals.

NOTE: Specifications may change without prior notice.



Manufactured by NEWMED

Via Lenin, 79/A
42020 Quattro Castella (RE) - Italy

Phone: +39 0522 875166

E-mail: NEWMED.SALES@MIDMARK.COM

WWW.MIDMARK.COM

MIDMARK STERILIZERS ARE IN COMPLIANCE WITH:

93/42/CEE	Medical Device Directive (MDD)
2014/68/EU	Pressure Equipment Directive
2012/19/EU	Waste electrical and electronic equipment (WEEE)
EN 13060	Small steam sterilizers
CEI EN 61010-1	Safety prescriptions for electrical, measuring, control and laboratory equipment
CEI EN 61010-2-040	Safety requirements for electrical equipment for measurement, control, and laboratory use - Part 2-040: Particular requirements for sterilizers and washer disinfectors used to treat medical materials
CEI EN 61326-1	Electrical equipment for measurement, control and laboratory use - Prescriptions of electromagnetic compatibility

